

TINED WEEDER PRO

**VS 470 M1, VS 600 M1, VS 750 M1, VS 900 M1,
VS 1200 M1**

OPERATOR MANUAL



PLEASE READ CAREFULLY BEFORE INITIAL OPERATION

Original operating manual

Version: 2.1 EN; item number: 00602-3-742



TABLE OF CONTENTS

1	EC DECLARATION OF CONFORMITY	4
2	IDENTIFICATION OF THE IMPLEMENT	5
3	SERVICE	5
4	WARRANTY	6
4.1	Warranty activation	6
5	SAFETY INFORMATION	6
5.1	Intended use	6
5.2	General safety-related instructions and accident prevention regulations	7
5.3	Mounted implements	8
5.4	Hydraulic system	9
5.5	Maintenance	9
5.6	Tyres	10
5.7	Mounted seeders	10
5.7.1	Filling the seeder	10
6	INFORMATION SIGNS / HAZARD LABELS	11
6.1	Information signs	11
6.2	Hazard labels	12
7	OPERATING INSTRUCTIONS	12
7.1	Mounting on the tractor	12
7.2	Safe parking	13
7.3	Securing the top link pin	13
7.4	Folding the Tined Weeder Pro	13
7.5	Working position and setting the working depth	14
7.6	Hydraulic tine adjustment	15
7.7	Additional adjustment options for ground adaptation	16
7.8	Adjusting the feeler wheel track	16
8	MAINTENANCE AND CARE	17
8.1	General maintenance instructions	17
8.2	Regular maintenance instructions	17
8.3	Changing the tines	18
8.4	Changing the spring assembly	18
8.4.1	Spring assembly without bolted fastening	18
8.4.2	Spring assembly with bolted fastening	19
8.5	Repairs and service	20
9	INFORMATION ON NATURE CONSERVATION AND ENVIRONMENTAL PROTECTION	20
10	TECHNICAL DATA	20
10.1	Harrow array widths	21
10.2	Combination options for the Tined Weeder Pro with pneumatic seeders (PS)	22
11	HYDRAULIC DIAGRAM	23
12	ROAD TRANSPORT OF THE TINED WEEDER PRO	26
12.1	Transport on public roads (general information)	26
12.2	Calculation of the weight ratios for axle loads on the tractor and ballast weights	26
12.3	Table for the weight ratios	28

13	LIGHTING CIRCUIT DIAGRAM	28
14	DECOMMISSIONING, STORAGE AND DISPOSAL	29
14.1	Decommissioning the implement	29
14.2	Storage of the implement	29
14.3	Disposal.....	29
15	CROPPING TIPS FOR USING THE TINED WEEDER PRO	29
16	ACCESSORIES	30
16.1	Warning signs and lighting	30
16.2	Bracket mounting kit for the pneumatic seeder	30
16.3	Dispersion plate bracket accessories kit	31
16.4	Platform kit for the Tined Weeder Pro	31
16.5	Linkage sensor top link accessories kit MX.....	31
16.6	GPSa sensor mounting kit	32
16.7	Tined Weeder Pro wheel sensor mounting kit	32
16.8	Rear feeler wheels	32
16.9	Carbide tines.....	32
16.10	Manual tine lifting.....	33
16.11	Lower link extension accessories kit	33
16.12	Additional weights accessories kit.....	33
16.13	Protective sticker for PS500 hopper.....	34
16.14	Half-side folding accessories kit.....	34
16.15	V folding accessories kit.....	34
16.16	Rear feeler wheels for the side frames.....	34
16.17	Precision preloading technology with linear motion flow divider	35
17	SPARE PARTS	36
18	INDEX	37

1 EC DECLARATION OF CONFORMITY



according to Machinery Directive 2006/42/EC
and Low Voltage Directive 2006/95/EC



APV-Technische Produkte GmbH
Dallein 15
A-3753 Hötzelstdorf

hereby declares that the mounted implement model series described in the following comply with the applicable basic safety and health requirements of the above-mentioned Directives in terms of their concept and design as well as the versions put on the market.

This declaration loses its validity if there are any changes to the mounted implement that are not approved by APV-Technische Produkte GmbH.

Designation of the mounted implement model series:

TINED WEEDER PRO VS 470 M1
TINED WEEDER PRO VS 600 M1
TINED WEEDER PRO VS 750 M1
TINED WEEDER PRO VS 900 M1
TINED WEEDER PRO VS 1200 M1

Serial numbers:

Starting at 07032-01000 - starting at 07018-01000 - starting at 07019-01000 - starting at 07020-01000 -
starting at 07014-01000

Year of manufacture: as of **2021**

Relevant EC Directives:

Directive for machinery – Machinery Directive 2006/42/EC

For the planning, design, construction and marketing of the mounted implements VS 600 M1 to VS 1200 M1, the following harmonised European standards were applied in addition to the Directives, in particular:

EN ISO 12100:2010 – Safety of machinery, general principles for risk assessment
EN ISO 13857:2020 – Safety distances to prevent hazard zones being reached by upper and lower limbs

EN ISO 13849-1:2015 – Safety of machinery – Safety-related parts of control systems

Responsible for the technical documentation: Planning and Design department, Dallein 15

Ing. Jürgen Schöls
Managing Director
(authorised person in the EU)

Dallein/Hötzelstdorf, 15.02.2023

2 IDENTIFICATION OF THE IMPLEMENT

The Tined Weeder Pro can be clearly identified by the following information on the type plate:

- Designation
- Model
- Production number

Position of the type plate

The type plate can be found on the inside of the main frame on the left in the direction of travel, on the front hollow profile (see Figure 1).



Figure 1

The following image (Figure 2) shows the layout of the type plate.



Figure 2

The data on the type plate have the following meaning:

- 1: Designation
- 2: Model
- 3: Production number / serial number
- 4: Weight
- 5: Year of manufacture



NOTE!

In cases of inquiries or warranty claims, please always tell us the production number/serial number of your implement.

3 SERVICE

Please contact our service address in the following cases:

- If you still have questions regarding the handling of this implement despite the information provided in this operating manual
- For questions regarding spare parts
- To order maintenance and servicing work

Service address:

APV – Technische Produkte GmbH
Zentrale: Dallein 62
A-3753 Hötzelzdorf
AUSTRIA

Telephone: +43 2913 8001-5500
Fax: +43 2913 8002
E-mail: service@apv.at
Web: www.apv.at

4 WARRANTY

Please check the implement for any transport damage immediately upon receipt. Later claims regarding transport damage can no longer be considered.

Based on a warranty activation (see Point 4.1), we grant a six-month factory warranty starting on the date of initial operation (your invoice is the warranty certificate).

This warranty is applicable for cases of material or construction faults and does not include parts that are damaged by normal or excessive wear.

The warranty expires

- if damage is caused by external forces.
- in cases of operating errors.
- if the kW/HP limits are significantly exceeded.
- if the implement is modified, expanded or equipped with third-party spare parts without our permission.

4.1 WARRANTY ACTIVATION

Every APV implement must be registered immediately after delivery. The registration activates the claim for warranty services and APV can guarantee the best service.

To activate the warranty for your implement, simply scan the QR code with your smartphone - you will then be taken directly to the service area on our website.



Of course, you can also activate the warranty through our website www.apv.at in the service area.

5 SAFETY INFORMATION

This chapter contains general rules of conduct for the intended use of the implement and safety-related information that should always be observed for your safety.

The list is very extensive, and some of the information does not apply exclusively to the delivered implement. However, the summary of the information often reminds you of unconsciously neglected safety regulations for the everyday operation of machines and implements.

5.1 INTENDED USE

The Tined Weeder Pro VS 470 M1 to VS 1200 M1 is designed and built for use in agricultural operations.

Its tines penetrate in the soil and loosen it, and where applicable, remove any existing weeds.

Any other use is considered to be non-intended. The manufacturer is not liable for any resulting damage, the operator alone bears the associated risk.

Examples of non-intended use include:

- The implement may not be used on grassland, it is only designed for use on fields within the specified framework conditions.
- The maximum working speed is 12 km/h.
- Driving in curves is not permitted.
- The VS may not be pushed back when in working position. Rolling back must also absolutely be avoided when starting to drive.
- Attention must be paid that the side frames do not hit the ground when turning at the headlands.
- Before parking the implement on the ground, it must be ensured that the tines are in transport position and that the implement is aligned parallel to the ground (top link).
- The implement may not be set down on the ground at a standstill when the tines are pre-tensioned in working position. Setting down on the ground is only permitted while driving forward.

- The implement may not be folded when the tines are pre-tensioned.
- When the tines are set down on the ground, the pre-tension may not be reduced when the implement is at a standstill. This is not a problem while driving forwards.

Intended use also includes compliance with the conditions for operation, maintenance, and repairs prescribed by the manufacturer.

The implement may only be used, maintained and repaired by persons who have relevant experience and were instructed on the risks. Be sure to hand over the safety instructions to other users.

The applicable, country-specific accident prevention regulations as well as the other generally safety-related, occupational health and road traffic regulations must also be observed.

The manufacturer is not liable for any damage resulting from unauthorised modifications and the use of components and auxiliary parts. This causes the declaration of conformity to lose its validity.

5.2 GENERAL SAFETY-RELATED INSTRUCTIONS AND ACCIDENT PREVENTION REGULATIONS

- **The operator has read and understood this operating manual before handling the implement.**
- **The operator must train and instruct their personnel. The personnel must have read and understood this operating manual before handling the implement.**
- Always keep the operating manual close to the implement for reference purposes.
- When passing on the implement, be sure to pass on the operating manual.
- Do not use the implement if you are tired or under the influence of drugs, alcohol or medication.
- **Check the implement and the tractor for road and operational safety before every use (e.g. defective parts, connections, hoses, protective equipment, etc.)!**
- **Before each use, the folding device and its safety devices (securing chain) must be checked for proper function and effect.**
- Inspections before and during operation as well as regular care and maintenance of the implement must be performed.
- Observe the generally applicable safety and accident prevention regulations for the respective country!
- The implement may only be used by persons who are informed of the hazards and who know the regulations for transport on public roads.
- The warning and information signs applied to the implement provide important instructions for safe operation. These may not be removed in any case, observe them for the sake of your own safety!
- Observe the respective country-specific road traffic regulations when using public roads!
- **Before starting work, get to know all of the equipment and operating elements as well as their functions. It is too late to do so during operation!**
- The user should wear close-fitting clothing. Avoid wearing loose clothes!
- Keep the implements clean to reduce the risk of fire!
- Always secure the parked implement against unintentional rolling.
- Check the surrounding area before starting up and operating the implement! (Children!) Ensure sufficient visibility!
- It is not allowed to carry passengers on the implement during operation and transport!
- The implement may only be climbed onto when a platform kit is installed.
- When using the platform kit, it must be ensured that the implement is at a standstill, is unfolded, and lowered onto the ground.
- It is forbidden to transport working materials on the implement!
- The implement must be coupled according to the instructions and only onto the specified devices!
- Special care must be taken when coupling and uncoupling implement to and from the tractor!
- When mounting and dismounting, put the support devices in their respective positions! (Stability)
- Always attach ballast weights at the intended attachment points according to the specifications!
- Observe the permissible axle load, total weight and transport dimensions!

- Transport equipment - e.g. lighting, warning signs and any protective equipment, must be checked and mounted!
- Never leave the driver's platform while driving!
- The driving behaviour, steering and braking capacity are affected by mounted or towed implements and ballast weights. For this reason, always ensure sufficient steering and braking capacity!
- When driving in curves, take account of the wide radius and/or the centrifugal mass of the implement (pay attention to the minimum turning curve)!
- The implement may only be operated when all of the protective devices are installed and in safety position!
- It is forbidden to stand in the working area of the implement!
- Do not stand near rotating and swivelling parts of the implement!
- Hydraulic folding frames may only be actuated when nobody is standing in the swivelling range.
- There are pinch and shear points on externally powered (e.g. hydraulic) parts!
- On implements with manual folding, always ensure that the implement is stable!
- For implements that are driven rapidly with soil-driven tools - Danger after lifting due to the still rotating centrifugal mass! Only approach the implement when it has come to a standstill!
- Before exiting the tractor, lower the implement onto the ground, switch off the motor and remove the ignition key!
- Standing between the tractor and the implement is forbidden unless the vehicle is secured against rolling away using the parking brake and/or with wheel chocks!
- Folded frames and lifting devices must be locked in transport position!
- Packer hooks must be swivelled in and locked before road transport!
- Lock the track markers in transport position!
- The view on the mounted harrow and the hazardous movement area must be clear to check the procedure.
- Cleaning is recommended as specified in the maintenance instructions (see point 8). The procedure in maintenance manual must be observed and protective equipment must be used.
- Working under the implement is forbidden – especially when it is lifted.
- The implements must be checked regularly by the operator (before every use) for any fractures and cracks, chafe marks, leaks, loose bolts and connections, vibrations, unusual sounds, and to ensure they function correctly.
- Safety glasses and hearing protection should be used.
- During assembly, the operator must ensure that the requirements for the tractor in terms of the power, axle loads and weight distribution as specified in the operating manual are met and that the connections specified in the operating instructions are made correctly.
- When mounting the implement, the operator must ensure that connections to the tractor hydraulic system are clean and carefully connected.
- It must be ensured that the hydraulic couplings are not soiled.
- When performing the work passes, the tractor's speed must be maintained as specified in the operating instructions. This can be between 1 and 12 km/h.
- Additional lighting (e.g., flashlight) should be used for repair or maintenance work if necessary.
- When implement parts are moving (e.g. during the folding or pre-tensioning procedure) it must be ensured that there is no one standing in the danger zone of the implement – there is a risk of crushing.
- When driving through low or narrow obstacles (e.g. power lines, underpasses, etc.), attention must be paid to the height and width of the implement to avoid collisions.
- In case of loss or breakage of implement parts, they must be immediately replaced with original parts by trained specialist personnel.

5.3 MOUNTED IMPLEMENTS

- Before mounting and dismounting implements on the three-point linkage, the operating devices must be moved into the correct position that excludes unintentional lifting or lowering!
- For three-point mounting, the mounting categories of the tractor and the implement must match or be adapted!
- There is a risk of injury due to crushing and shearing points in the area of the three-point linkage!

- Do not stand between the tractor and the implement when actuating the external controls for the three-point mounting!
- When the implement is in transport position, always ensure that the tractor three-point linkage is sufficiently locked to the sides!
- When driving on roads with the implement lifted, the operating lever must be locked against lowering!
- When mounting the implement, the operator must ensure that there is a metallic connection (ensured by the lower link) made to the tractor.
- The operator must ensure that no one is standing close to the implement when it or its components are being moved by the tractor hydraulic system or when the side wings are being lifted or lowered. Visual check by the driver!
- When driving on roads, which is only permitted with the implement lifted and with folded side wings, the control block on the hydraulic cylinder prevents lowering of the implement as well as of the folded up side wings (additionally secured with a chain). The secured chain also prevents accidental lowering of the side frame during road transport in case of failure of the tractor hydraulic system.
- Mounting of any sort of accessories onto the implement must be performed according to standards. The maximum permitted total weight may not be exceeded.
- Only APV implements and accessories may be mounted on the implement.
- Accessories must be mounted in compliance with the standards by qualified specialist personnel from an authorised company.

5.4 HYDRAULIC SYSTEM

- **Inspect the hydraulic hose lines at regular intervals and replace in case of damage or wear! The replacement lines must comply with the technical requirements of the implement manufacturer!**
- The hydraulic system is under high pressure!
- When connecting hydraulic cylinders and motors, the specified connection of the hydraulic hoses must be observed!
- When connecting the hydraulic hoses to the tractor hydraulic system, make sure that the hydraulic system on the tractor and implement side is **unpressurised!**
- For hydraulic function connections between the tractor and implement, coupling sleeves and coupling plugs should be marked to exclude the possibility of operating errors! If the connections are interchanged, the function will be inverted (e.g. lifting/lowering)! – Danger of accident!
- Due to the risk of injury, use suitable tools when searching for leaks!
- Liquids escaping under high pressure (hydraulic oil) can penetrate skin and cause serious injuries! Consult a doctor immediately in case of injury! (Risk of infection!)
- Before working on the hydraulic system, park the implement, depressurize the system and switch off the motor!
- The securing chain should only be unhooked when it is relieved of tension (cylinder must be filled with oil)!

5.5 MAINTENANCE

- Maintenance, repair, and cleaning work as well as the elimination of malfunctions should always be performed when the drive is switched off and the motor is at a standstill and the implement is uncoupled from the towing vehicle! Remove the ignition key!
- The maintenance work itself may only be performed by trained specialist personnel and may never be performed alone. Extreme caution must be taken when changing defective components or tools.
- If repair or maintenance work is required on the implement, this work must be identified by a clearly visible information sign "Caution: maintenance work".
- Check the nuts and bolts regularly for tight fit and retighten if necessary!
- When performing maintenance on the lifted implement, always ensure safety against lowering through suitable support elements!
- When changing working tools with sharp edges, always use suitable tools and cut-resistant gloves!

- Replacing components that cannot be removed with tools such as a screwdriver or wrench may only be replaced by qualified specialist personnel from an appropriately authorised company or by APV Customer Service.
- Dispose of oils, greases and filters according to the national regulations!
- Always cut the power supply when working on the electrical system!
- When performing electrical welding work on the tractor and mounted implement, disconnect the cable on the generator and the battery!
- Spare parts must at least comply with the technical requirements specified by the implement manufacturer! This is ensured with original parts!
- Cleaning must be performed with water and/or compressed air. Cleaning must only be carried with the implement lowered, shut down and secured to prevent it being switched on again.

5.6 TYRES

- When working on the tyres, it must be ensured that the implement is safely parked and secured against rolling away (wheel chocks).
- The mounting of wheels and tyres requires sufficient knowledge and proper installation tools.
- Repair work on the tyres may only be performed by specialists and with suitable installation tools.
- Check the tyre pressure regularly. Observe the prescribed inflation pressure (2.1 bar)!

5.7 MOUNTED SEEDERS

- When using a seeder, all of the specifications of the implement manufacturer must be observed.
- The seeder can be easily reached with using a ladder and platform. They must be clean and dry during use.
- It is strictly forbidden to stand on the platform or its access ladder while driving.
- When not in use, the ladder must be folded up and secured.
- An ascent must be established conforming to the standards. This ascent is available from APV.

5.7.1 FILLING THE SEEDER

- The seeder is filled using a supply vehicle.
- The platform kit may not be used to fill the seeder or as a storage area for objects or seed.
- When filling the seeder, never stand under a suspended load!
- When driving up to the implement with seed, nobody may be standing on or around the implement.
- During the loading procedure, avoid any contact with the treated seed and wear gloves, a dust mask and safety glasses.







CAUTION!
Misprints, errors and omissions excepted.

6 INFORMATION SIGNS / HAZARD LABELS

Pay special attention to the stickers on the implement, as they warn you of specific dangers!

6.1 INFORMATION SIGNS

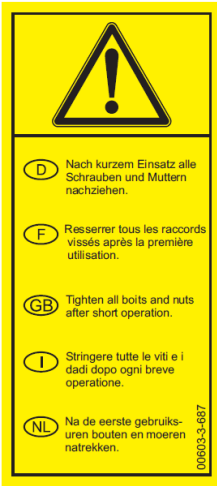
			
<p>Read and observe the operating manual before operating the implement!</p>	<p>Standing in the danger zone (swivelling range) is forbidden!</p>	<p>Always lift the implement slowly off the ground</p>	<p>Do not stand on the implement while driving!</p>

			
<p>Loading hooks. When loading the implement, attach the ropes or chains to these points!</p>	<p>Always switch off the engine and remove the key before maintenance work!</p>	<p>After a short period of operation, re-tighten all bolts and nuts.</p>	<p>Labelling of the grease nipple position</p>

6.2 HAZARD LABELS



Caution, crushing area!
Never reach into the
crushing danger zone as
long as the parts can
still move!

7 OPERATING INSTRUCTIONS

7.1 MOUNTING ON THE TRACTOR

Under difficult operating conditions, additional wheel weights can be useful. Please also refer to the operating manual from the tractor manufacturer.

The tractor should be equipped with sufficient ballast weight at the front to ensure the steering and braking capacity. At least 20% of the empty vehicle weight is required on the front axle.

The lifting struts must be adjusted to the same height on the left and on the right. The implement must be mounted on the 3-point linkage of the tractor.

Mount the top link so that it slants down towards the tractor during operation. (Observe the specifications from the tractor manufacturer).

To ensure correct connection of the hydraulic hoses for the tine pre-tensioning, the hoses are labelled as follows:

- 1 red cable tie: return flow (A, -)
- 2 red cable ties: supply (B, +)

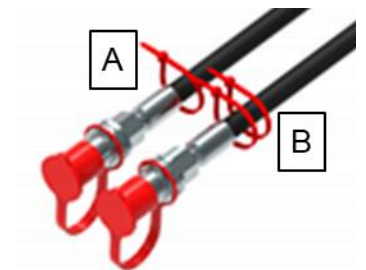

Figure 3

7.2 SAFE PARKING

- The parking surface must be suitable for parking the implement. The ground must be firm and level, so that the stands do not sink in and the harrow does not roll away.
- To ensure safe parking of the implement, lower the stands at the rear of the harrow.
- Make sure that the tines do not touch the ground in the process to prevent damage to the tines or the tine mounts.
- The stand must be secured with a spring cotter on the pin to prevent accidental loosening.
- The securing chains must be hooked onto the side frames, and the ball valves on the folding cylinders must be locked to prevent accidental lowering of the side frame (see Figure 5 and Figure 6).
- Then the hydraulic hoses to the tractor must be depressurised and uncoupled.

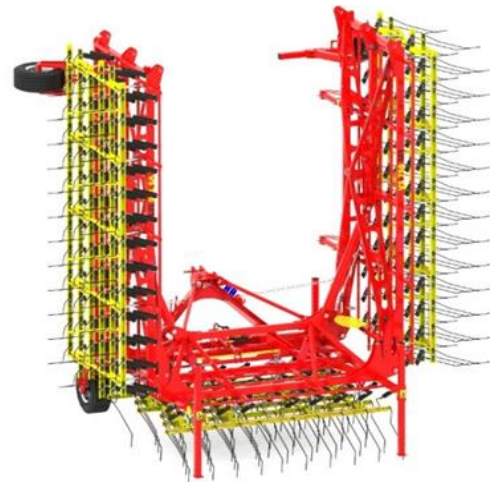

Figure 4



NOTE!

When uncoupling the hydraulic hoses for the tine pre-tensioning under pressure, first close the stop tap, and only then unplug the hydraulic hoses. By doing so, the tines remain in the desired position, even when the harrow is parked.



Figure 5: ball valve open



Figure 6: ball valve closed

7.3 SECURING THE TOP LINK PIN

When the Tined Weeder Pro is mounted on the tractor, the washer marked in Figure 7 must always be placed on the spring cotter on the top link! Otherwise, the implement can be released from the tractor.



CAUTION!

The elongated slot must only be used for operation! For road transport, use the round hole underneath.



Figure 7

7.4 FOLDING THE TINED WEEDER PRO

1. The implement can only be folded when it is raised from the ground.
2. Ensure that no one is standing in the danger area!
3. Couple the hydraulic line plugs (ensure that they are always kept clean!).
4. Afterwards, fill the cylinder with oil (fold together). The cylinders are filled as soon as the load on the securing chains is relieved.
5. Unhook the securing chains.
6. **When folding** into transport position, the implement must also be lifted from the ground and the **harrow tines must be folded up** (pre-tensioning -3).
7. The feeler wheels on the side frame must be completely raised before the harrow can be folded in order to maintain the permissible transport width.
8. Hook on the securing chains again after the harrow has been folded (see Figure 8).

CAUTION!

The tines may be pre-tensioned only when the Tined Weeder Pro is unfolded.

During the folding procedure, first the outer side frame is folded by 180° onto the inner frame, which is then folded up by 90°.

If the implement is unfolded into working position, the hydraulic control units and/or the double-acting hydraulic control units must be moved to the "N - neutral" position.



Figure 8

CAUTION!

To achieve a transport width of less than 3 m, the feeler wheels on the first side frame must be completely moved up in the feeler wheel bracket.

NOTE!

When uncoupling the hydraulic hoses for the tine pre-tensioning under pressure, first close the stop tap, and only then unplug the hydraulic hoses. By doing so, the tines remain in the desired position, even when the harrow is parked.



Figure 9: Folding of the Tined Weeder Pro

7.5 WORKING POSITION AND SETTING THE WORKING DEPTH

The harrow intensity is set with the pre-tensioning of the spring pack. The pre-setting is made hydraulically and comfortably from the tractor seat. On the scale (see Figure 10), the driver can read the level that is currently set. Here, the springs are not pre-tensioned at positions -3 to 0. Pre-tensioning begins at 0, and the full pre-tension is reached at position 6. At position -3, the tines are folded up, which means that the tines are in transport position.

The working speed has a significant effect on the intensity of harrowing. The normal speed range is between 1 and 12 km/h, depending on the crop sensitivity and growth stage.

The feeler wheels can be moved on the frame to the desired track width. The clearance and the tine angle can be adjusted using the pattern of holes in the feeler wheels.

The higher the feeler wheels are moved up in the frame, the smaller the distance between the frame and the ground and the steeper the position of the tine ends relative to the ground.

To set all of the feeler wheels, including those at the rear, to the same height, the same number of holes must be visible above the bracket on all of the feeler wheels.

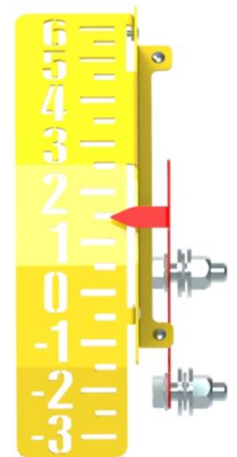

Figure 10



Figure 11: Working position



NOTE!

When the feeler wheels are moved further down, the clearance is increased and the tine angle becomes steeper, and therefore more aggressive. The tine pressure remains the same.



NOTE!

Ideally, there should almost be a right angle (90° - 100°) between the wearing end of the tine and the soil (see Figure 12 - centre). Because of the pre-tensioning, this angle is only reached while driving.

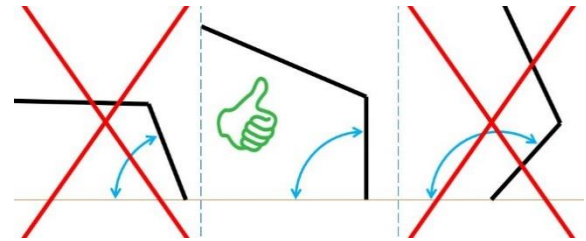

Figure 12: An angle of 90° - 100° is ideal

All of the tine rows should penetrate the soil at the same depth (working depth), i.e. the frame must run parallel to the ground.

To achieve this, the extension of the top link must also be adjusted. The parallelism of the frame to the ground can be read on the spirit level on the centre frame, provided that you are on a horizontal plane.



CAUTION!

Only set the harrow with pre-tensioned springs on the ground when the vehicle is already in motion. If the harrow is set down on the ground too rapidly at a standstill, there can be damage to the implement.



CAUTION!

When the harrow is lowered, do not allow it to push or roll back with the tractor; otherwise, the tines and bearing points can be damaged.



CAUTION!

After longer stretches of road transport or standstill, there can be differences in the pre-tension in the hoses due to a change in temperature of the oil. For this reason, pre-tension the tines completely and then loosen them again completely two times. Then you can set the desired pre-tension (e.g. Level 2). This has to be done when the implement is lowered onto the ground.



CAUTION!

Driving in curves is not permitted. If there is no other option, these curves must be driven in a very large radius.



CAUTION!

The working speed may not exceed 12 km/h.

7.6 HYDRAULIC TINE ADJUSTMENT

The tines are adjusted with multiple hydraulic cylinders connected in parallel. This allows the tine pre-tension to be changed while driving.

All of the hydraulic cylinders (Figure 13) are connected by an oil circuit. Adjustments are made using a double-acting control unit and the flow divider on the centre frame (Figure 14).

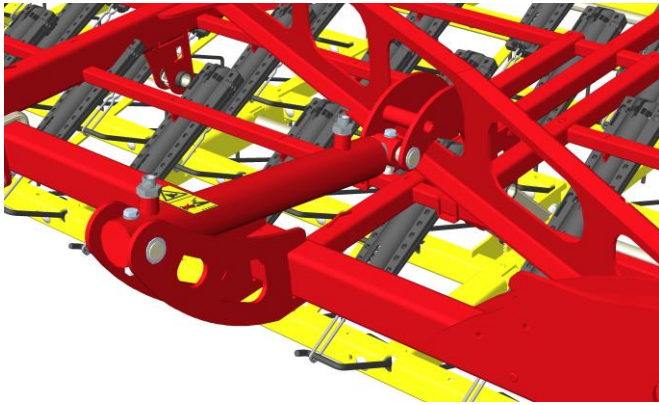

Figure 13: Hydraulic cylinder



Figure 14: Flow divider on the centre frame

CAUTION!

With the combination of the VS 1200 M1 with a mounted pneumatic seeder, there is a risk of collision when the tines are preloaded. This can result in material damage to the tines and bearing points. NEVER fold the implement when the tines are preloaded. NEVER preload the tines when the implement is folded.

7.7 ADDITIONAL ADJUSTMENT OPTIONS FOR GROUND ADAPTATION

The slot in the cylinder working point on the side frame further improves the ground adaptation of the Tined Weeder Pro. If the laterally bolted, folding locking plates are installed, the upward ground adaptation of the side frame is fully available, but the downward ground adaptation is limited. This has the advantage that the harrow sags less, which is helpful when turning. If the plates are removed, the ground adaptation is fully available in both directions.

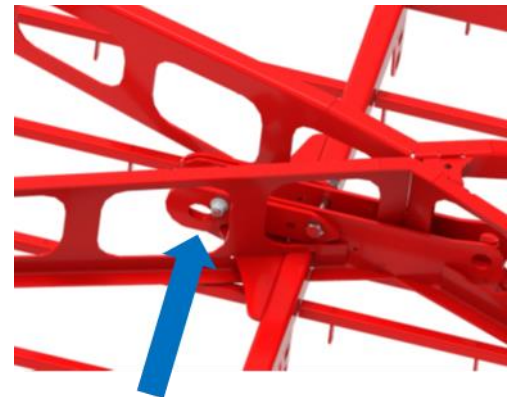

Figure 15: Folding locking plate on the side frame

7.8 ADJUSTING THE FEELER WHEEL TRACK

To set the desired track width for the feeler wheels, the nuts on the U brackets of the feeler wheel brackets must be loosened. Then the feeler wheel bracket and the section are pushed into the desired position and the nuts are retightened.



Figure 16

CAUTION!

The nuts on the U brackets of all feeler wheel brackets on the Tined Weeder Pro may only be tightened to a maximum of 25 Nm to avoid damage to the U bracket.

8 MAINTENANCE AND CARE

8.1 GENERAL MAINTENANCE INSTRUCTIONS

To maintain the implement in good condition even after a long service life, the following instructions must be observed:

- In Point 5, you will find some basic safety regulations for maintenance work.
- Original parts and accessories are designed especially for the machines or implements.
- Please note that original spare parts and original accessories not supplied by us have also not been tested and approved by us.
- The installation or use of such products can therefore possibly negatively change or impede the constructional properties of your implement. The manufacturer rules out any liability for damages resulting from the use of non-original parts and accessories.
- The manufacturer is not liable for any unauthorised modifications to the implement and the use of components and auxiliary parts on the implement that were not purchased from APV.
- **Before every commissioning, check the hydraulic hose lines for wear, damage and ageing. Damaged or faulty parts must be immediately replaced.**
- When replacing the hydraulic hose lines, original spare parts must be used that comply with the technical requirements of the implement manufacturer.
- Caution! Liquids escaping under high pressure can penetrate the skin. For this reason, a physician must be consulted immediately in case of accident!
- After cleaning, lubricate all of the grease points and distribute the grease evenly in the bearing points (e.g. perform a short test run).
- Do not use a high pressure cleaner to clean bearing and hydraulic parts.
- The paint can be damaged by cleaning with excessive pressure.
- During the winter, the implement should be protected against corrosion with an environmentally-friendly product.
- Park the implement protected from weather conditions.
- Put down the implement in a way that the tines are not needlessly strained.
- **Hydraulic hose lines must be replaced at the latest 6 years after their manufacturing date. The manufacturing date of the hydraulic hose lines is specified on the fittings.**
- Hydraulically as well as mechanically folded implement must only be parked in a folded state.
- The hydraulic system must be inspected at least once a year by specialist personnel.

8.2 REGULAR MAINTENANCE INSTRUCTIONS

- All bolted connections should be re-tightened at the latest after 3 operating hours and again after 20 hours, and then checked regularly. Loose bolts can cause significant consequential damage, which is not covered by the warranty.
- The grease points on the joints and bearings must be lubricated regularly (approx. every 10 operating hours with universal grease).
- After the first 10 operating hours and subsequently every 50 operating hours, the hydraulic units, hoses and couplings as well as tube lines must be checked for leaks and the bolted connections must be tightened if necessary.
- Occasionally check the tyre inflation pressure (2.1 bar).
- The platform kit and its access ladder must be visually inspected on a regular basis.
- The rubber for fastening the access ladder of the platform kit must be checked regularly for wear and replaced if necessary.



NOTE!

When the implement is lifted off of the ground, the two side wings of the frame should be pointing slightly down. If this is not the case or if the wings are pointing down too much, the stop bolts on the joint must be adjusted.

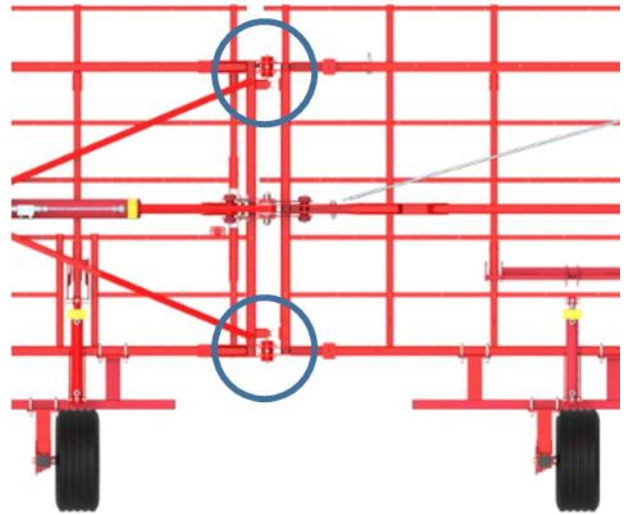

Figure 17

8.3 CHANGING THE TINES

To change broken or worn tines:

Loosen the nut (1) on the plastic piece (2).

Pull the bearing unit (bolt + nut + bearing shell) and the tines out of the frame.

Assembly is performed in the reverse sequence.

The recommended tightening torque for the nut is of 3 Nm. Ensure that the nut is not tightened too much, so that the tine can fall downward with its net weight. If this is not the case, the tine cannot work properly when the pre-tension is low.

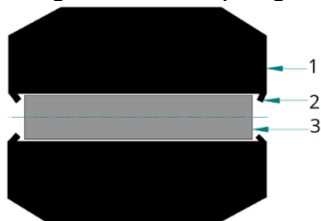

Figure 18: 1 = nut, 2 = plastic piece

8.4 CHANGING THE SPRING ASSEMBLY

8.4.1 SPRING ASSEMBLY WITHOUT BOLTED FASTENING

Diagram of the spring fastening:



- 1: Spring assembly plastic shell
- 2: Snap-fit
- 3: Fastening bolt

Figure 19

1. Step:

Unlock the snap-fits on one side of the spring assembly. To do so, press from the side in the hole in the spring assembly with a bolt or a pin (8 mm diameter) – as shown in Figure 20 – until the pins touch. As a result, the snap-fits on one side are unlocked.

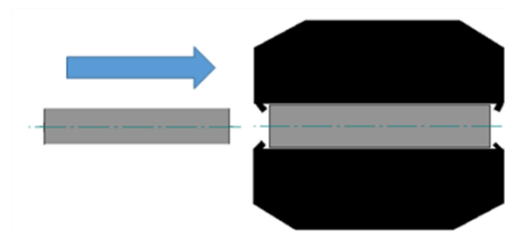

Figure 20: Step 1

2. Step:

Push the pin out of the spring assembly. To do so, press with a bolt or a pin (8 mm diameter) into the hole in the spring assembly on the opposite side. Now all of the pins can be pulled out of the spring assembly, and the entire spring assembly is released from the frame.

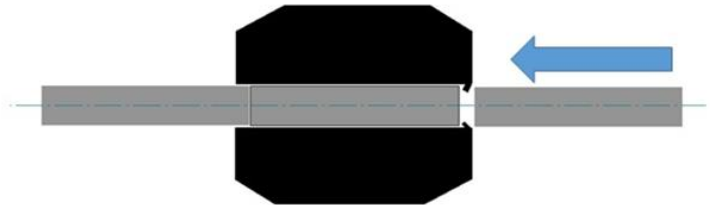

Figure 21: Step 2

3. Step:

To install the new spring assembly, it must first be put in position. Then the fastening bolt is pressed into the hole in the spring assembly as shown in Figure 22.

Ensure that all of the snap-fits are locked again. This is the case when the fastening bolt is pressed far enough into the hole. It may be necessary to press it in further using a bolt or a pin (8 mm diameter).

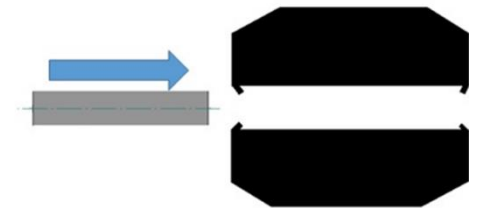
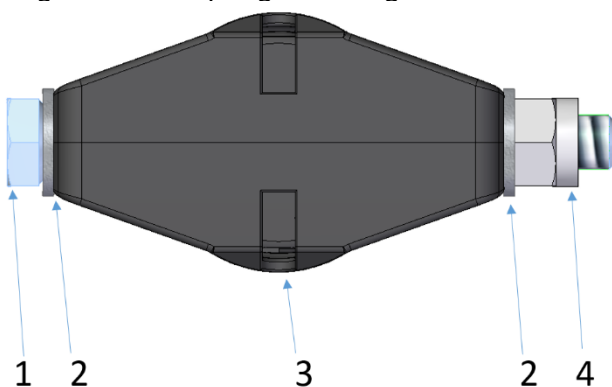

Figure 22: Step 3

8.4.2 SPRING ASSEMBLY WITH BOLTED FASTENING

Diagram of the spring fastening:



- 1: Bolt M8x85
- 2: Washer M8
- 3: Spring assembly plastic shell
- 4: Lock nut M8

Figure 23

- Loosen the lock nut (4) with a wrench (width across flats 13).
- Pull the bolt (1) out of the spring assembly.
- Pull the spring assembly (3) out of the tine and replace it with a new one.
- Insert the bolt (1) through the new spring assembly (3) and retighten the nut (3).

CAUTION!

Only tighten the nut far enough so that the washers are resting on the spring assembly. In no case should a gap be produced between the half shells due to excessive tightening.

8.5 REPAIRS AND SERVICE

In case of failure or damage to the implement, please contact the manufacturer. The contact data can be found in chapter 3.

9 INFORMATION ON NATURE CONSERVATION AND ENVIRONMENTAL PROTECTION

Reduction of noise pollution during use

Any loose parts (e.g. chains) should be attached to prevent unnecessary noise.

Energy-efficient use

The tines of the implement should not penetrate into the field deeper than necessary. By doing so, the towing vehicle is not unnecessarily strained and fuel can be saved.

Recyclable raw materials during disposal

Many parts of the implement are made of steel or spring steel (such as the centre frame, side frame, tine section, tines, ...) and can be accepted and recycled by a waste disposal plant.

10 TECHNICAL DATA

Type designation	VS 470 M1	VS 600 M1	VS 750 M1	VS 900 M1	VS 1200 M1
Mode of operation	With its unique tine spring system, the Tined Weeder Pro is a crop cultivation implement that adapts precisely to the ground. The harrow tines can be lifted and are pivot-mounted, so that the harrow can only deflect up and down, not to the left and right.				
Working width [m]	4.9	6.2	7.6	9.2	12.2
Transport dimensions, folded [H x W x D in m]	2.15 x 3.00 x 2.40	2.85 x 3.00 x 2.40	3.55 x 3.00 x 2.40	3.55 x 3.00 x 2.40	3.55 x 3.00 x 2.40
Working depth	0-30 mm (depending on the soil conditions)				
Number of tines [units]	140	178	218	264	350
Tine diameter [mm]	8				
Tine length [mm]	520				
Line distance [mm]	35				
Mounting/hitch	Mounting – CAT 2 / CAT 2N				
Feeler wheels, standard equipment [unit]	4	4	4	4	6
Net weight [kg]	810	900	1050	1300	1550
Parking supports	2 supports, if no feeler wheels are used at the rear				
Working tools	Cranced tines with a diameter of 8 mm				
Ground adaptation	Is achieved through the unique tine spring system				

Type designation	VS 470 M1	VS 600 M1	VS 750 M1	VS 900 M1	VS 1200 M1
Minimum tractor performance [kW/HP]	44 / 60	44 / 60	51 / 70	63 / 85	74 / 100
Can be equipped with	PS 120 M1 – PS 500 M2 (see Point 10.2)				

10.1 HARROW ARRAY WIDTHS

VS470:

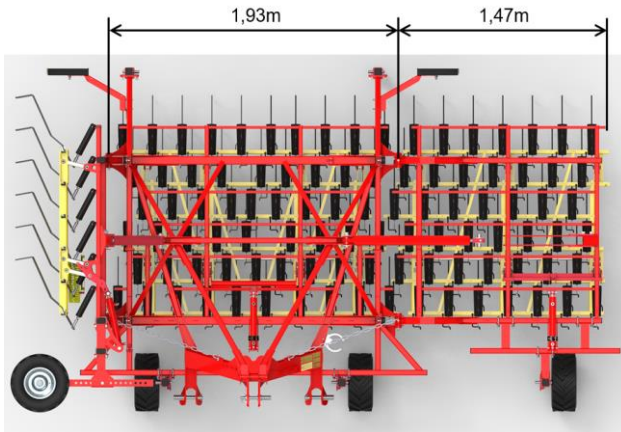

Figure 24: VS470

VS600:

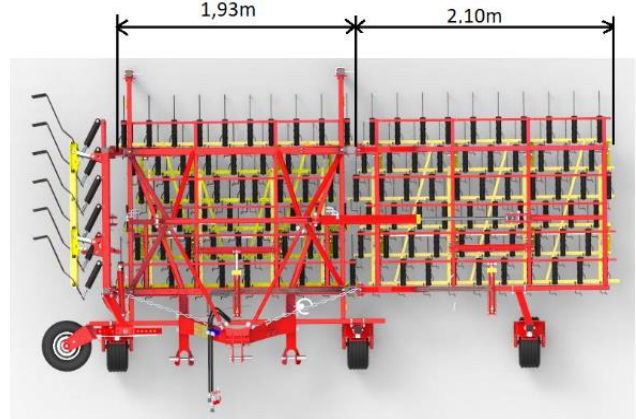

Figure 25: VS600

VS750:

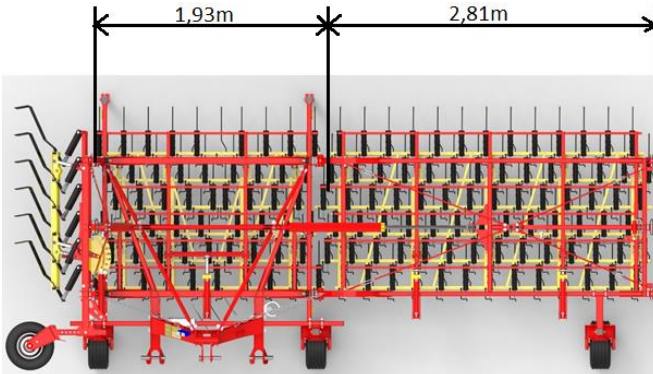

Figure 26: VS750

VS900:

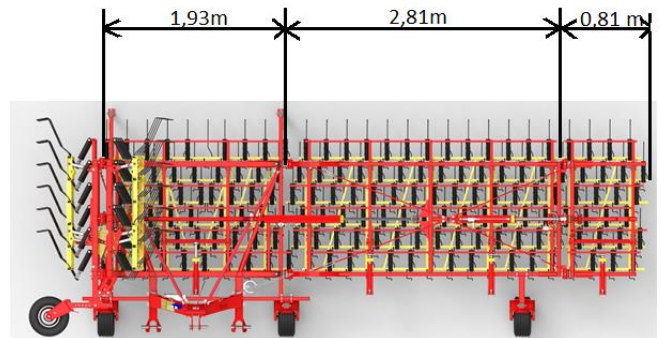

Figure 27: VS900

VS1200:

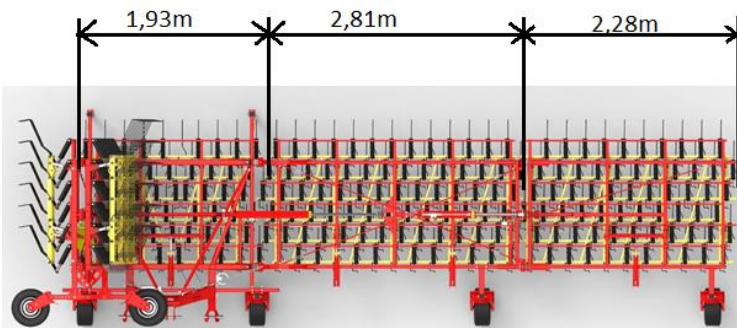

Figure 28: VS1200

10.2 COMBINATION OPTIONS FOR THE TINED WEEDER PRO WITH PNEUMATIC SEEDERS (PS)

PS	PS 120 E	PS 200 E	PS 200 H	PS 300 E	PS 300 H	PS 500 E	PS 500 H	
Dimensions PS HxWxD [cm]	90x60x80	100x70x90	100x70x110	110x80x100	110x80x115	125x80x120	125x80x125	
Weight [kg]	45	60	83	70	93	93	116	
VS	Combined state: Transport dimensions WxDxH [cm] and weight [kg]							Parts for mounting
VS 470 M1 810	300x240x285 855	300x240x285 870	300x240x285 893	300x240x285 880	300x240x285 903	300x240x285 903	300x240x285 926	Mounting kits for PS see Chapter 16
VS 600 M1 900	300x240x285 945	300x240x285 960	300x240x285 983	300x240x285 970	300x240x285 993	300x240x285 993	300x240x285 1,016	
VS 750 M1 1,050	Cannot be combined	Cannot be combined	300x240x355 1,133	Cannot be combined	300x240x355 1,143	Cannot be combined	300x240x355 1,166	
VS 900 M1 1,300			300x240x355 1,383		300x240x355 1,393		300x240x355 1,416	
VS 1200 M1 1,550			300x240x355 1,633		300x240x355 1,643		300x240x355 1,666	

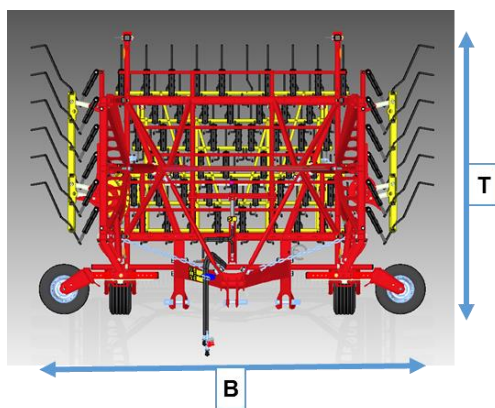

Figure 29: Tined Weeder Pro - Top view in transport position

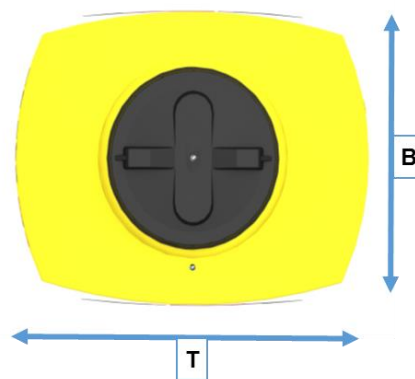

Figure 30: Pneumatic seeder - Top view

B: Width
T: Depth

11 HYDRAULICDIAGRAM

VS 470 M1, VS 600 M1

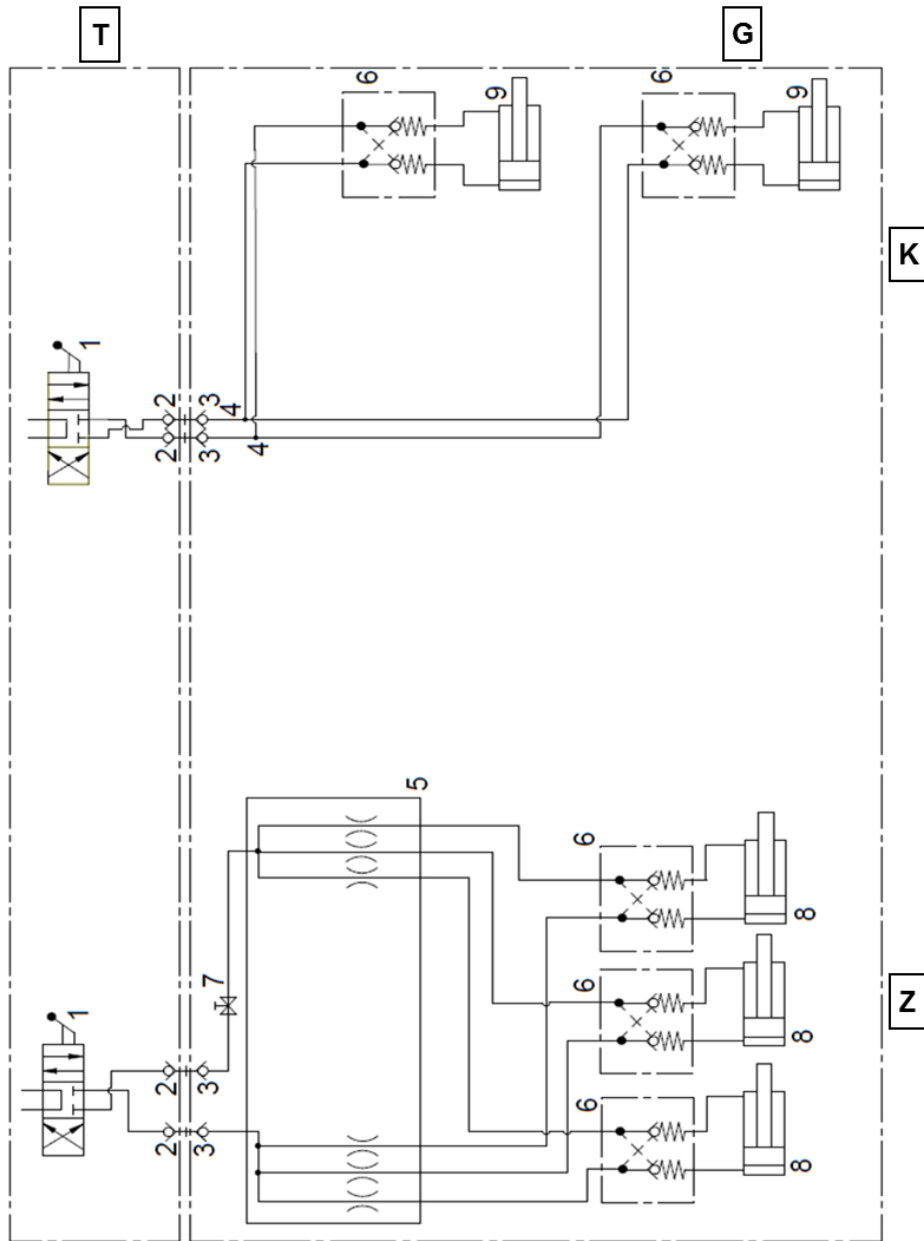

Figure 31: Hydraulic diagram VS 470 M1 and VS 600 M1

T	Tractor-side	4	T-connection
G	Implement-side	5	3-way flow divider
K	Folding	6	Locking block
Z	Tine adjustment	7	Ball valve
1	Control unit	8	Double-acting cylinder for tine adjustment
2	Coupling sleeve BG 2	9	Double-acting cylinder for folding
3	Coupling plug BG 2		

VS 750 M1

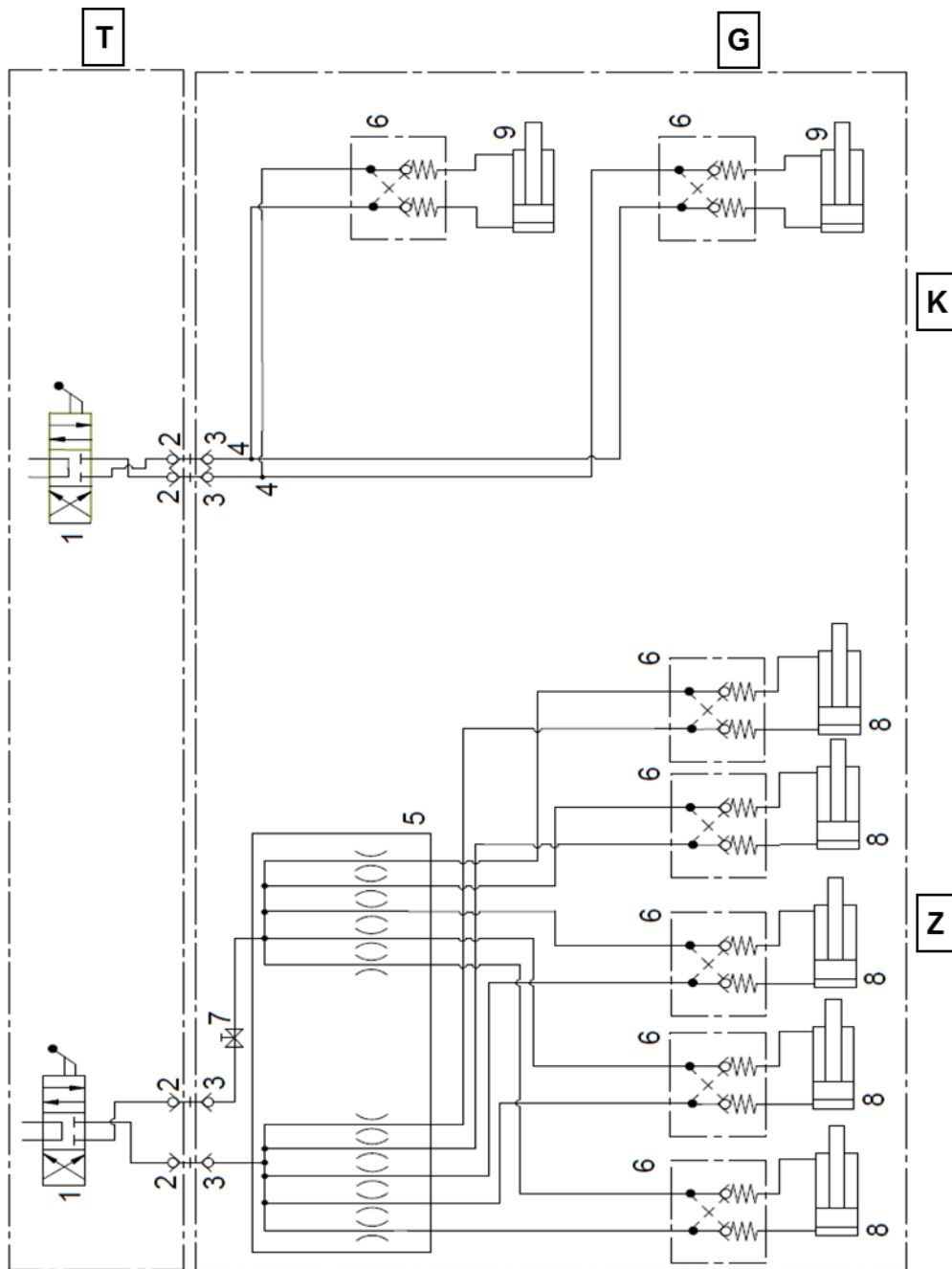

Figure 32: Hydraulic diagram VS 750 M1

T	Tractor-side	4	T-connection
G	Implement-side	5	3-way flow divider
K	Folding	6	Locking block
Z	Tine adjustment	7	Ball valve
1	Control unit	8	Double-acting cylinder for tine adjustment
2	Coupling sleeve BG 2	9	Double-acting cylinder for folding
3	Coupling plug BG 2		

VS 900 M1 and VS 1200 M1

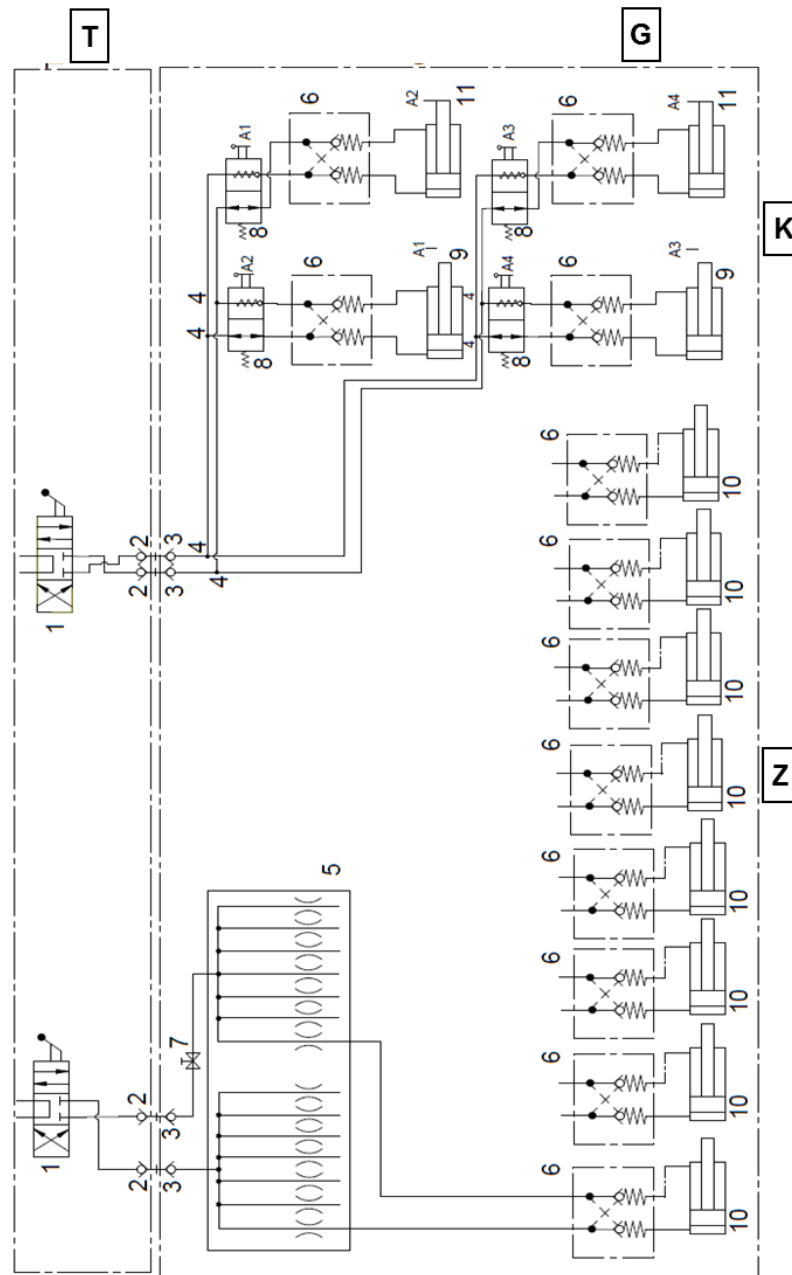

Figure 33: Hydraulic diagram VS 900 M1 and VS 1200 M1

T	Tractor-side	5	7-way flow divider
G	Implement-side	6	Locking block
K	Folding	7	Ball valve
Z	Tine adjustment	8	Stroke limiter
1	Control unit	9	Double-acting cylinder for folding, inside
2	Coupling sleeve BG 2	10	Double-acting cylinder for tine adjustment
3	Coupling plug BG 2	11	Double-acting cylinder for folding, outside
4	T-connection		

12 ROAD TRANSPORT OF THE TINED WEEDER PRO

12.1 TRANSPORT ON PUBLIC ROADS (GENERAL INFORMATION)

- When driving on roads after field operation, the tine sections should be cleaned of harrowing residues (soil, grass, etc.).
- Comply with the road traffic regulations of your country's legislation.
- The mounted implement must be identified with country-specific warning signs or stickers with red and white slanted lines (according to DIN, ÖNORM or the respective country-specific STANDARDS).
- Any part posing a traffic hazard or dangerous parts (tines) must be covered and identified.
- Lighting equipment of the towing vehicle may not be hidden by the implement; otherwise, they must be installed on the mounted implement.
- Warning signs or stickers should be visible at a height of max. 150 cm above the road when driving.
- The bracket for the warning signs (additional equipment) is mounted on the centre frame (see section 16 Accessories).
- The axle load and the total weight of the towing vehicle may not be exceeded.
- The steering capacity of the tractor must not be impeded or reduced by the mounted implement!
- Semi-mounted implements may only be towed on public roads with an operating permit.
- Hydraulic implements must be folded in transport position (tine pre-tensioning).
- Ensure that the stop tap (if equipped) is closed or the securing chains are hooked.
- Only relieve the hydraulic hoses shortly before uncoupling the tractor by putting the tractor control unit into float position.
- Only relieve the hydraulic hose at home by putting the tractor control unit into float position.
- Also ensure that none of the safety splints were lost during operation.

CAUTION!

The Tined Weeder Pro may not be transported when the top link pin is in the elongated slot!

For road transport, the bolt must be installed in the round hole (underneath the elongated slot) and secured against loss with a cotter pin.



Figure 34



Figure 35

12.2 CALCULATION OF THE WEIGHT RATIOS FOR AXLE LOADS ON THE TRACTOR AND BALLAST WEIGHTS

If you want to drive with an implement that is attached to the 3-point linkage, you must ensure that you do not exceed the tractor's maximum permissible total weight, the permissible axle loads and tyre load capacities with the mounted implement.

The front axle of the tractor must be loaded with at least 20 % of the net weight of the tractor.

The necessary ballast weight as well as the actual axle loads can be determined using the following formulas:

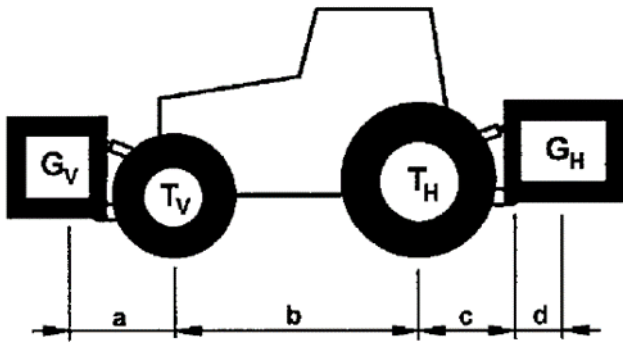

Figure 36

Specifications:

- T_L Tractor net weight
- T_V Front axle load of the empty tractor
- T_H Rear axle load of the empty tractor
- G_H Total weight of the rear-mounted implement
- G_V Total weight of the front-mounted implement
- a Distance from the centre of gravity of the front-mounted implement to the centre of the front axle
- b Wheelbase of the tractor
- c Distance from the centre of the rear axle to the centre of the lower link ball
- d Distance from the centre of the lower link ball to the centre of gravity of the rear-mounted implement
($d = 97$ cm)

WEIGHT CALCULATIONS

1. Calculating the minimum front ballasting on rear-mounted implements $G_{V \min}$:

$$G_{V \min} = \frac{G_H \cdot (c + d) - T_V \cdot b + 0,2 \cdot T_L \cdot b}{a + b}$$

This result is entered in the table under Point 12.3.

2. Calculation of the minimum rear ballasting for front-mounted implements $G_{H \min}$:

$$G_{H \min} = \frac{G_V \cdot a - T_H \cdot b + 0,45 \cdot T_L \cdot b}{b + c + d}$$

This result is also entered in the table under Point 12.3.

3. Calculation of the actual front axle load $T_{V \text{tat}}$:

If the required minimum front ballast ($G_{V \min}$) is not reached with the front-mounted implement (G_V), the weight of the front-mounted implement must be increased to the weight of the minimum front ballast!

$$T_{V \text{tat}} = \frac{G_V \cdot (a + b) + T_V \cdot b - G_H \cdot (c + d)}{b}$$

Now enter the calculated actual front axle load and the permissible front axle load specified in the tractor operating manual in the table under Point 12.3.

4. Calculation of the actual total weight G_{tat} :

If the required minimum rear ballast (G_H) is not reached with the rear-mounted implement ($G_H \min$), the weight of the rear-mounted implement must be increased to the weight of the minimum rear ballast!

$$G_{\text{tat}} = G_V + T_L + G_H$$

Now enter the calculated total weight and the permissible total weight specified in the tractor operating manual in the table under Point 12.3.

5. Calculation of the actual rear axle load $T_{H \text{tat}}$:

$$T_{H \text{tat}} = G_{\text{tat}} - T_{V \text{tat}}$$

Now enter the calculated actual rear axle load and the permissible rear axle load specified in the tractor operating manual in the table under Point 12.3.

6. Tyre load capacity:

Enter the doubled value (two tyres) for the permissible tyre load capacity (see e.g. tyre manufacturer documents) in the table under Point 12.3.

CAUTION!

The minimum ballast must be attached to the tractor as a mounted implement or ballast weight!
The calculated values may not be higher than the permissible values!

12.3 TABLE FOR THE WEIGHT RATIOS

	Actual value acc. to calculation		Permissible value acc. to operating manual		Double the permissible tyre load capacity (2 tyres)
Minimum ballast front/rear	kg				
Total weight	kg	≤	kg	≤	kg
Front axle load	kg	≤	kg	≤	kg
Rear axle load	kg	≤	kg	≤	kg

The minimum ballast must be attached to the tractor as a mounted implement or ballast weight!
The calculated values may not be higher than the permissible values!

13 LIGHTING CIRCUIT DIAGRAM

Legend:

R	Right
1	12 V plug, 7-pin
2	Rear light, right
2.1	Turn signal
2.2	Rear light
2.3	Brake light
L	Left
3	Rear light, left
3.1	Brake light
3.2	Rear light
3.3	Turn signal

Plug and cable assignment:

No.	Desig.	Colour	Function
1	L	Yellow	Turn signal, left
2	54g	---	---
3	31	White	Earth
4	R	Green	Turn signal, right
5	58R	Brown	Rear light, right
6	54	Red	Brake light
7	58L	Black	Rear light, left

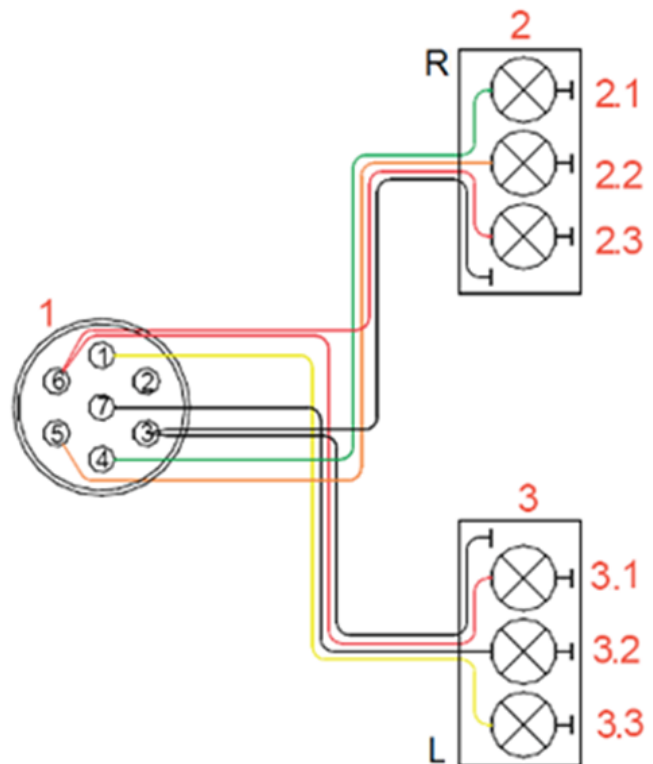

Figure 37: Circuit diagram

14 DECOMMISSIONING, STORAGE AND DISPOSAL

14.1 DECOMMISSIONING THE IMPLEMENT

To ensure that the implement remains fully functional, even if it is out of operation for longer periods of time, it is important to take precautions for storage: To do so, observe Point 7.2.

14.2 STORAGE OF THE IMPLEMENT

- The implement must be stored in a dry place protected from weather conditions to ensure that it remains functional even if it is stored for a longer period of time.
- The implement must be parked in compliance with Point 7.2.
- Secure the implement against unintentional rolling away.
- Nothing may be deposited or stored on the implement.
- The implement must always be parked and stored in a secure area, to prevent unauthorised operation.

14.3 DISPOSAL

Disposal of the implement must be performed according to the local disposal regulations for machines.

15 CROPPING TIPS FOR USING THE TINED WEEDER PRO

The Tined Weeder Pro's mode of action mainly consists of burying and uprooting the weeds and crumbling the soil surface. It also stimulates tillering in cereals. Compared to hoeing machines, the Tined Weeder Pro has two major benefits: It operates in a row-independent manner and has a comparatively high area efficiency.

The seed rate and surface structure of the seedbed are very closely related to the success of harrowing against weeds. Whereby shallow seeding excludes any pre-emergence harrowing. When the plants are firmly rooted in the soil later on, harrowing can be performed again. At seeding depths of 3-4 cm, pre-emergence harrowing is possible when the working width of the harrow is shallower. However, the germinating seed may not be touched by the harrow tines during operation.

In general, the objective is to control weeds by harrowing at the root hair or cotyledon stage during the growing season while protecting the crops as much as possible. The optimal mode of operation to achieve this strongly depends on the soil, crop, and weather conditions. The optimal site-dependent mode of operation can be found fastest by adjusting the working depth and varying the working speed. As a basic setting on the harrow, the tips of the tines should be about vertical to the soil surface (see chapter 7.5 Working position and setting the working depth).

Warnings against excessive harrowing intensity are an increased number of uprooted, buried or bent plants. Low crop losses can be compensated in advance through a slight increase in the seed rate of about +10%. After finishing all field passes, the final crop density should not drop below the cropping-related required values.

Other effects of tilling your fields with the Tined Weeder Pro, such as

- Soil aeration,
- Regulation of the water balance,
- Incorporation of the seed for nurse crops and
- Promoting tillering in cereals

make a significant contribution to the formation of good crops.

Summary for efficient and effective harrowing:

- Important prerequisites are a level seedbed, sufficiently deep seed placement, uniform germination, loose soil surface, few tracks, and suitable weather conditions.
- A missed harrowing pass can NOT be performed at a later date.
- Harrowing does not have a lasting effect => several consecutive work passes must be coordinated.
- Optimal harrowing takes place at the limit of crop tolerance, in case of doubt, enumerate the crop plant losses.
- When seeding, account for crop plant losses.
- The weed controlling effect of the harrow is sometimes already achieved at low forward speeds (above approx. 1-2 km/h).
- Optimal adjustment of the harrow can take a lot of time.

Only the potential of harrowing is described here! Ultimately, harrowing success depends on the skill and experience of the operator.

16 ACCESSORIES

The accessories must be mounted by qualified specialist personnel or a specialist workshop. The customer/dealer must ensure that the accessories are properly mounted.

16.1 WARNING SIGNS AND LIGHTING

For the Tined Weeder Pro, warning signs with lighting are also available as an accessory. These are required when you want to drive with the Tined Weeder Pro on public roads.

Order number:

- 07014-2-501: Standard lighting
- 07026-2-006: LED lighting VS
- 07014-2-693: LED lighting VS front + rear

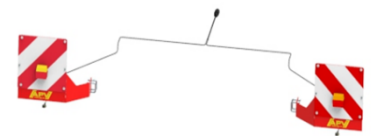

Figure 38

16.2 BRACKET MOUNTING KIT FOR THE PNEUMATIC SEEDER

This bracket is used to mount a pneumatic seeder PS 120 M1 – PS 500 M2 on the Tined Weeder Pro. Please note that it must be mounted in compliance with the standards.

Order number:

07014-2-385: PS bracket accessories kit



Figure 39

16.3 DISPERSION PLATE BRACKET ACCESSORIES KIT

This is used to mount the dispersion plates on the Tined Weeder Pro.

Order number:

- 07032-2-029: Dispersion plate accessories kit for VS470 (contains 8 dispersion plate brackets)
- 07018-2-033: Dispersion plate accessories kit for VS 600 M1 (contains 8 dispersion plate brackets)
- 07019-2-011: Dispersion plate accessories kit for VS 750 M1 (contains 16 dispersion plate brackets)
- 07020-2-035: Dispersion plate accessories kit for VS 900 M1 (contains 16 dispersion plate brackets)
- 07014-2-298: Dispersion plate accessories kit for VS 1200 M1 (contains 16 dispersion plate brackets)

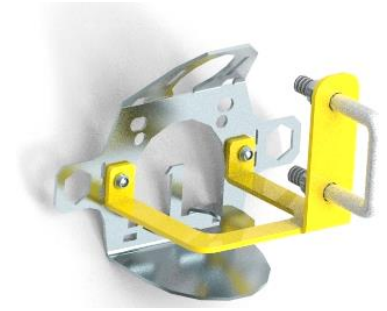

Figure 40

16.4 PLATFORM KIT FOR THE TINED WEEDER PRO

For easier maintenance of the Pneumatic Seeder PS 120 M1 - PS 500 M2, a suitable platform kit is available as an accessory.

Please note that it must be mounted in compliance with the standards.

Order number:

- 07014-2-386: Platform kit for VS without feeler wheels at the rear
- 07014-2-387: Platform kit for VS with feeler wheels at the rear



Figure 41

16.5 LINKAGE SENSOR TOP LINK ACCESSORIES KIT MX

In combination with a pneumatic seeder, this sensor can be used to automatically stop the seeding shaft when lifting the implement at the headlands.

Order number:

00410-2-169



Figure 42

16.6 GPSA SENSOR MOUNTING KIT

In combination with a pneumatic seeder, this sensor can be used for speed-dependent seed application.

Order number:
06001-2-064



Figure 43

16.7 TINED WEEDER PRO WHEEL SENSOR MOUNTING KIT

In combination with a pneumatic seeder, this sensor can be used for speed-dependent seed application or to stop the seeding shaft of a pneumatic seeder when lifting the implement at the headlands.

Order number:
07000-2-059



Figure 44

16.8 REAR FEELER WHEELS

In order to improve the guidance of the harrow along the ground, height-adjustable feeler wheels can be used at the rear. The feeler wheels are mounted on a crossbeam and can therefore be infinitely variably adjusted to the track width.

Order number:

- 07014-2-384: Accessories kit for rear feeler wheels
- 07014-2-565: Accessories kit rear inner feeler wheels



Figure 45

16.9 CARBIDE TINES

A 60 mm-long carbide plate is soldered onto the wearing end of the tine, which significantly reduces tine wear.

Order number:

- 07032-2-023: Carbide tines accessories kit for VS 470 M1
- 07018-2-034: Carbide tines accessories kit for VS 600 M1
- 07019-2-012: Carbide tines accessories kit for VS 750 M1
- 07020-2-036: Carbide tines accessories kit for VS 900 M1
- 07014-2-299: Carbide tines accessories kit for VS 1200 M1

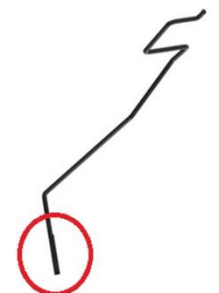

Figure 46

16.10 MANUAL TINE LIFTING

With the manual tine lifting, individual tines can be lifted (see Figure 47), e.g. to avoid working in rows where the plants are already taller. As a result, the harrow can be optimally adjusted for crops grown on beds.

Either the entire harrow can be equipped or any number of tine lifting mechanisms can be selected. To actuate the tine lifting mechanism, lift the tine and simply push the plate towards the tine.



Figure 47

Order number:

- 07032-2-025: Tine lifting accessories kit for VS 470 M1
- 07018-2-047: Tine lifting accessories kit for VS 600 M1
- 07019-2-015: Tine lifting accessories kit for VS 750 M1
- 07020-2-049: Tine lifting accessories kit for VS 900 M1
- 07014-2-363: Tine lifting accessories kit for VS 1200 M1
- 07014-2-351: individual tine lifting

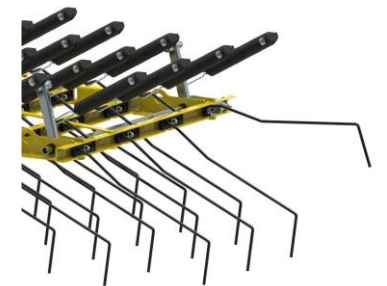

Figure 48

16.11 LOWER LINK EXTENSION ACCESSORIES KIT

The lower link extension is attached to the lower links of the implement using a pin and enables higher lifting of the implement on the headlands.

Please note: Use of the lower link extension increases the transport height of the implement by up to 20 cm.

Order number:

07014-2-558



Figure 49

16.12 ADDITIONAL WEIGHTS ACCESSORIES KIT

Under extremely hard soil conditions, the additional weights can be installed on the outer side frame of the VS1200 to improve the harrowing results.

Order number:

07014-2-567



Figure 50

16.13 PROTECTIVE STICKER FOR PS500 HOPPER

When a PS500 is mounted on the VS1200, the protective stickers are required to protect the hopper from damage during road transport.

Order number:
07014-2-646

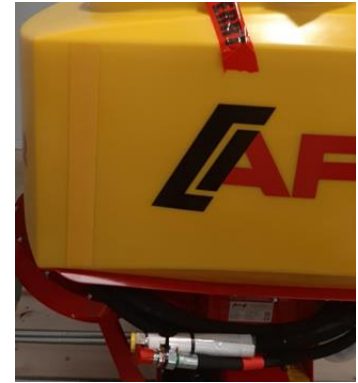

Figure 51

16.14 HALF-SIDE FOLDING ACCESSORIES KIT

With an additional double-acting hydraulic control unit, the implement can be folded on one side.

Order number:

- 07014-2-632: Half-side folding for VS470, VS600, VS750
- 07018-2-087: Half-side folding for VS900, VS1200



Figure 52

16.15 V FOLDING ACCESSORIES KIT

With an additional double-acting hydraulic control unit, the implement can be folded in a V shape. This can be beneficial on the headlands because the side frames can then be lifted more quickly from the ground, thus preventing impacts during the turning procedure.



Figure 53

Order number:
07014-2-582

16.16 REAR FEELER WHEELS FOR THE SIDE FRAMES

Additional rear feeler wheels are available for the side frames of the Tined Weeder Pro.

Each feeler wheel bracket has a turning device with which the feeler wheel can be swivelled to the rear. This allows a transport width of less than 3 m to be reached.

Please note: The rear feeler wheels for the side frames must be folded to the rear with the turning device before road transport!

Order number:

- 07014-2-565: Can be used for VS470, VS600, VS750, VS 900 and the first side frame of the VS1200
- 07014-2-566: Can be used for the second side frame of the VS1200



Figure 54

16.17 PRECISION PRELOADING TECHNOLOGY WITH LINEAR MOTION FLOW DIVIDER

The linear motion flow divider optimises the precision of the preloading compared to the standard preloading.

Please note:

On implements with linear motion flow divider, it is not possible to shut off the hydraulic tine adjustment in the individual tines sections.

With the combination of the VS 1200 M1 with a mounted pneumatic seeder, there is a risk of collision when the tines are preloaded.

This can result in material damage to the tines and bearing points.

NEVER fold the implement when the tines are preloaded.

NEVER preload the tines when the implement is folded.

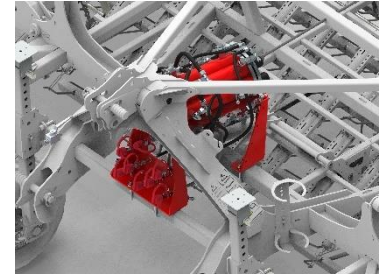

Figure 55

Order number:

- 07020-2-101: Linear motion flow divider VS 900 M1
- 07014-2-853: Linear motion flow divider VS 1200 M1

17 SPARE PARTS

You have the option to order your required spare parts directly through our online spare parts catalogue. To do so, scan the QR code with your smartphone - you will be taken directly to our online spare parts catalogue. Please keep your product number / serial number at hand.

You can also view our online spare parts catalogue on our website www.apv.at in the Service area.

If you have any questions regarding spare parts or your order, our Customer Service (see point 3 for contact data) is also happy to assist you.



18 INDEX

Accessories	31	Minimum ballasting	27
Accident prevention regulations	7	Mounted implements	8
Bearing	30	Mounted seeders	10
Calculation of the weight ratios	26	Mounting	12
Changing the springs	18	Nature conservation and environmental protection	20
Changing the tines	18	Parking	13
Combination options	22	Plug and cable assignment	29
Conformity	4	Production number	5
Cropping tips	30	Recyclable raw materials	20
Disposal	30	Reduction of noise pollution	20
Driving in curves	15, 20	Repair	20
Energy-efficient use	20	Road transport	26
Feeler wheel track	16	Safety information	6
Flow divider	15	Safety-related instructions	7
Folding	13	Service	5, 20
Folding procedure	14	Setting the working depth	14
Ground adaptation	16	Snap-fit	19
Harrow array widths	21	Spare parts	37
Harrow intensity	14	Table for the weight ratios	29
Hazard labels	12	Technical data	20
Hydraulic cylinders	15	Tine angle	14
Hydraulic diagram	23	Top link pin	13
Hydraulic system	9	Track width	14, 16
Hydraulic tine adjustment	15	Transport position	14
Identification	5	Type plate	5
Information signs	11	Tyres	10
Intended use	6	Warranty	6
Lighting circuit diagram	29	Weight calculations	27
Maintenance	9	Working position	14, 30
Maintenance and care	17	Working speed	14
Maintenance and servicing work	5		



APV – Technische Produkte GmbH
Zentrale: Dallein 62
AT - 3753 Hötzelndorf

Tel.: +43 2913 8001
Email: office@apv.at
www.apv.at

